

OVERVIEW

Most truck OEMs currently offer engine return fuel as the heat source for the DAVCO Fuel Pro 382 (Figure 1). Current common rail engines generally do not have enough return fuel heat or flow rate to be used as a heat source for Fuel Pros.

Determine if the bottom plate is equipped with a fluid heat assembly. If the Fuel Pro 382 has a deep bottom plate (Figure 3) it is a heated assembly with a heater loop and can be upgraded to use coolant heat. If the bottom plate is flat (Figure 4), order the DAVCO fluid heat bottom plate upgrade kit, DAVCO P/N 382029-23DAV (Figure 5).

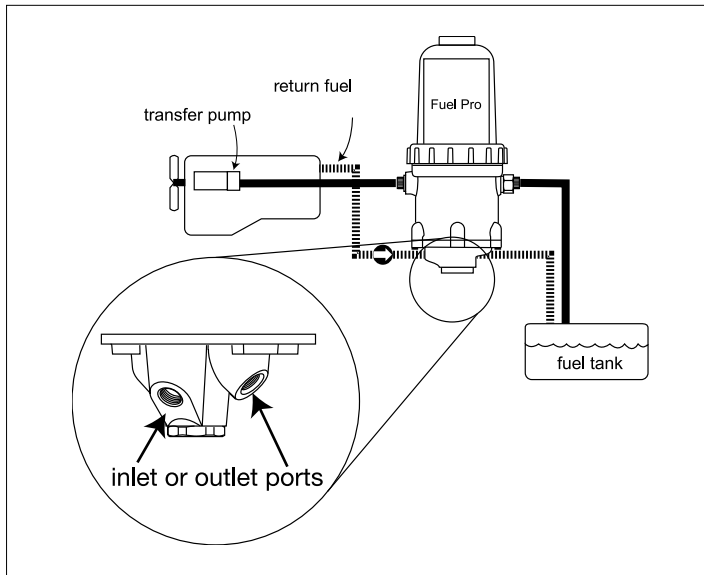

Figure 1: Return Fuel Heat

To address this, a DAVCO Fuel Pro 382 can be easily plumbed for engine coolant to provide adequate heat at the primary filter (Figure 2).

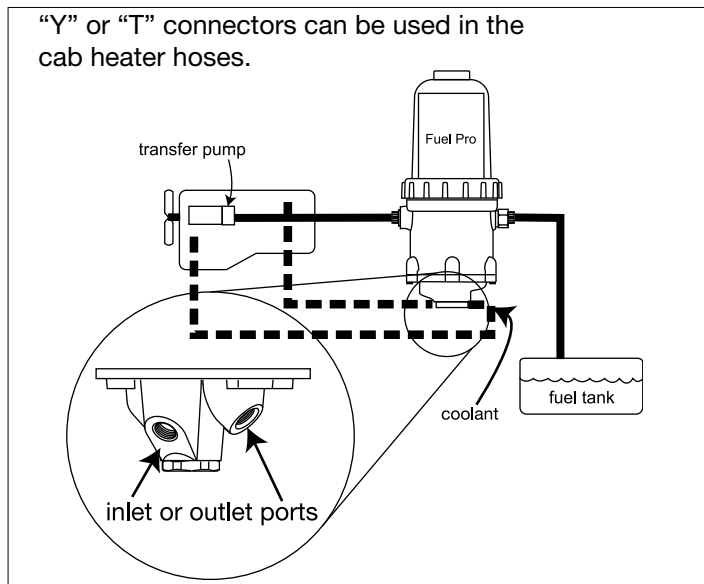

Figure 2: Coolant Heat

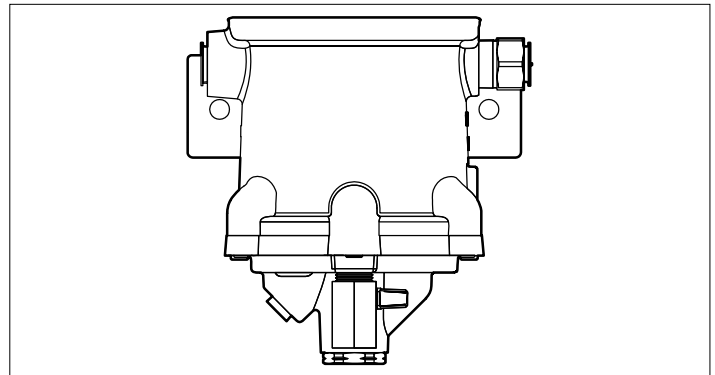

Figure 3: Fluid heat bottom plate

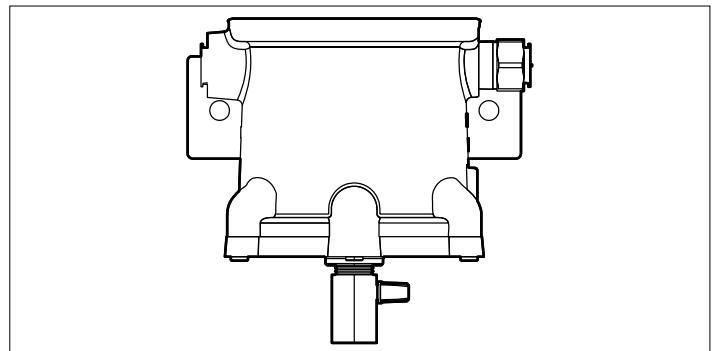

Figure 4: Flat bottom plate

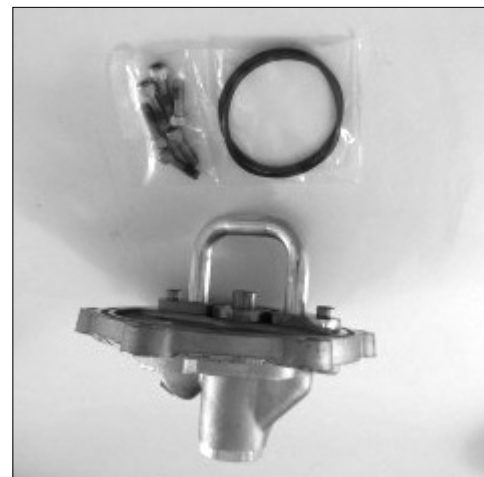

Figure 5: Kit P/N 382029SVCB

REMOVING/BYPASSING RETURN FUEL CONNECTIONS FROM FUEL PRO

PACCAR and DTNA Applications

Note: PACCAR and DTNA return fuel applications utilize a 3/8" NPT thread on the bottom plate.

Step 1: Disconnect the return fuel lines at the heater base on the bottom of the Fuel Pro 382/383 (Figure 6).

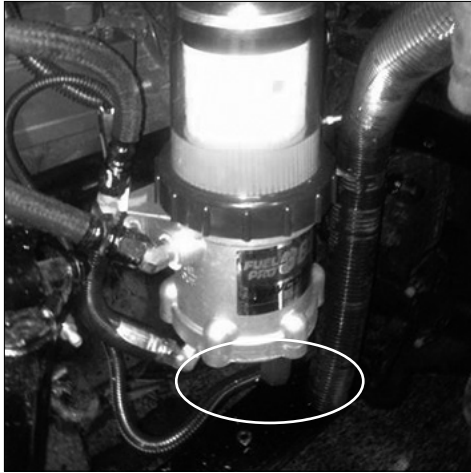

Figure 6: Disconnect Return Fuel Line

Step 2: Splice the return fuel lines together with the appropriate union. Use JIC style (PACCAR) (Figure 7) and Compression (DTNA) (Figure 8).

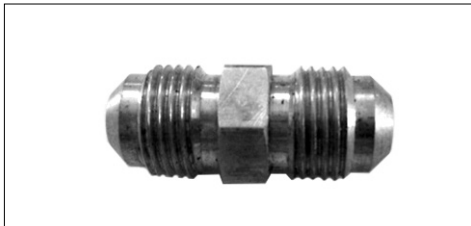

Figure 7: JIC Style (PACCAR)

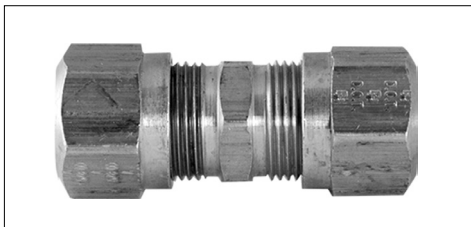

Figure 8: Compression (DTNA)

Step 3: Remove existing return fuel fittings from bottom plate of Fuel Pro (Figure 9).

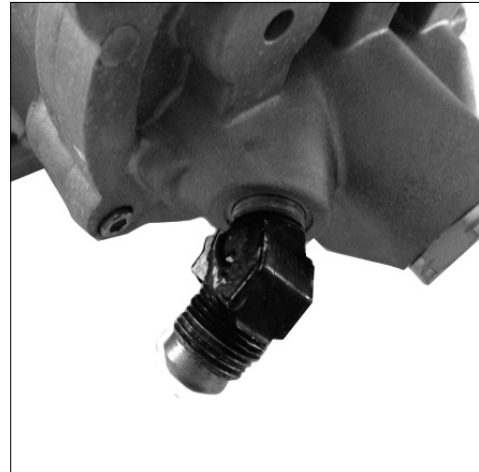

Figure 9: Return Fuel Fittings

REMOVING/BYPASSING RETURN FUEL CONNECTIONS FROM FUEL PRO

NAVISTAR Applications:

NAVISTAR return fuel applications utilize a 9/16-18 straight thread o-ring port on the bottom plate.

Step 1: Remove the VOSS quick connect fittings at the bottom plate by pushing the red release button in and pulling the hose end away from the VOSS fitting (Figure 10).



Figure 10: Voss Fitting on Bottom of Fuel Pro

Step 2: Remove the VOSS quick connect fitting at the return port on the engine and discard the hose (Figure 11).



Figure 11: Voss Fitting on Engine

Step 3: Carefully route the return line to the tank up to the return fuel port on the engine and connect (Figure 12).

Note: The hose end can spun/oriented as needed.



Figure 12: Re-route Return Fuel Line

Step 4: Remove VOSS return fuel fitting from bottom plate of Fuel Pro (Figure 13).

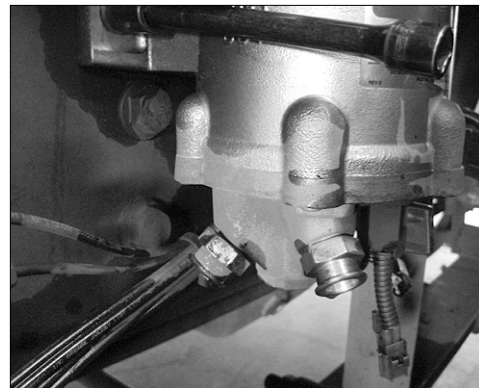

Figure 13: Remove Voss Fitting

INSTALLING COOLANT CONNECTIONS INTO FUEL PRO

PACCAR and DTNA Applications:

Step 1: Using liquid Teflon thread sealant install 3/8" NPT 90 ° 5/8" beaded hose barb fittings into each port on the bottom plate of the Fuel Pro.

Step 2: Orient the fittings so the 5/8" coolant hoses will clear surrounding components (Figure 14).

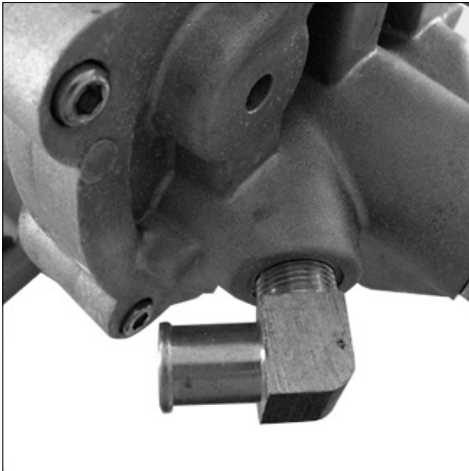

Figure 14: Beaded Hose Barb

Step 3: Flush fluid heater loop with water or coolant to rid of residual fuel and contaminants.

NAVISTAR Applications:

Step 1: Install Parker adapters 3/8-6 F50G into each port on the bottom plate of the Fuel Pro (Figure 15).

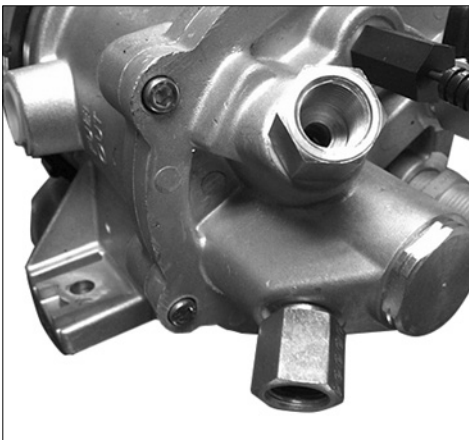

Figure 15: Parker Adapter 3/8-6 F50G

Step 2: Using liquid Teflon thread sealant install 3/8" NPT 90 ° 5/8" beaded hose barb fittings into each port on the bottom plate of the Fuel Pro (Figure 16).

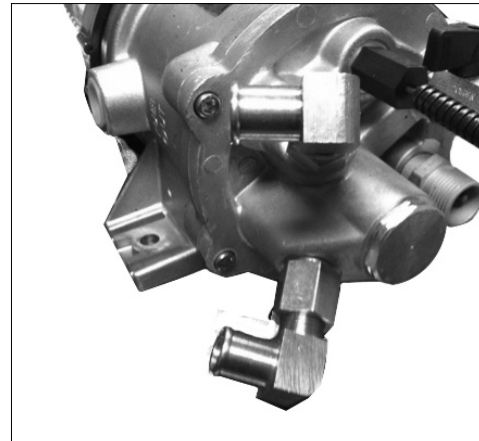

Figure 16: Install beaded hose barb fittings

Step 3: Flush fluid heater loop with water or coolant to rid of residual fuel and contaminants.

ENGINE OR TRUCK COOLANT CONNECTIONS

Cummins ISX

On a Cummins ISX, a coolant pressure plug (Figure 17) is located behind the turbo on the right hand side of the engine.



Figure 17: Location of coolant pressure plug

A coolant return plug is located at the water pump (Figure 18).



Figure 18: Location of coolant return plug

Step 1: Remove metric allen head o-ring plugs and install Parker P/N 169HB-10-MI27 6 fitting (Figure 19).



Figure 19: Parker fitting, P/N 169HB-10-MI27

Navistar MaxxForce or Paccar MX13

Note: On a Navistar MaxxForce or a Paccar MX13 engine, there are no accessible engine coolant ports and the cab heater circuit must be utilized (Figure 20 - Peterbilt application shown).



Figure 20: Cab heater circuit

Step 1: Using heater hose pliers, clamp off both sides of the intended tee location. Cut the 3/4" ID hose. Install a 3/4" x 3/4" x 5/8" tee (Figure 21) into the cab heater return hose.



Figure 21: 3/4" x 3/4" x 5/8" tee, P/N 103430DAV

Step 2: Using heater hose pliers, clamp off both sides of the intended tee location. Cut the 5/8" ID hose. Install a 5/8" x 5/8" x 5/8" tee (Figure 22) into the cab heater pressure hose.

⚠ **Caution:** Do not splice into the heater hose going to the emission aftertreatment unit.



Figure 22: 5/8" x 5/8" x 5/8" tee, P/N 103429DAV

COOLANT CONNECTIONS AT THE FUEL PRO

Step 1: Wrap with 1" Convoluted Tubing and route two pieces of 5/8" ID heater hose from the Fuel Pro 382 (Figure 23) to the tees at the cab heater circuit or the Cummins ISX block adapters (Figure 24), securing as needed.

Note: The Fuel Pro 382 heater ports are non-directional. Either port can be used for "in" or "out".

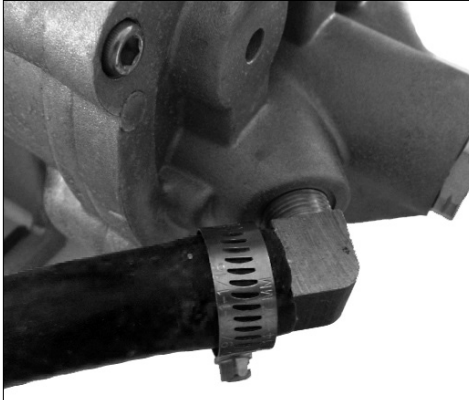

Figure 23: 5/8" heater hose on Fuel Pro 382



Figure 24: Secure the heater hose

Step 2: Remove the heater hose clamp pliers and start the engine. Check for leaks. Top off the surge tank as needed.