

INSTALLATION

This system must be installed between the fuel tank and the transfer fuel pump. This system can be used as the only fuel filter in the fuel system by removing the existing filter and heads, or remove the filters only and replace with special diverter caps.

Note: If the Fuel Pro is used as the primary filter and a secondary filter is required, secondary filter life may be extended.

PRE-INSTALLATION PRECAUTIONS

- ⚠ **Scalding hazard!** When diesel fuel is circulated through an operating engine, it can become very hot. Do not allow heated liquid fuel to come in contact with eyes or unprotected skin. Always allow the engine and fuel to cool to ambient temperature before replacing the fuel filter or performing service operations which could result in the spillage of fuel from the fuel system. If this is not possible, protective clothing (face shield, insulated hat, gloves, apron) must be worn.
- ⚠ **Fire Prevention!** To eliminate the potential for fire, keep open flames, sparks or other potential ignition sources away from the work area, and do not smoke during filter replacement or service operations which could result in the escape of diesel fuel or fuel vapors.
- ⚠ **Inhalation Prevention!** Always perform engine or vehicle fuel system maintenance in a well ventilated area that is kept free of bystanders.
- ⚠ The ignition key must be in the off position, unless otherwise specified in the instructions.
- ⚠ Dispose of diesel fuel and filters in an environmentally responsible manner, according to state and/or federal (EPA) regulations.

INSTALLATION OF THE FUEL PRO

Step 1: With the engine shut down and at ambient temperature, close the fuel shutoff valve (if equipped) and place a suitable container under the fuel filters.

Step 2: Remove the primary fuel filter element assembly, sedimenter, and/or water separator. Drain the used element and dispose of it in an environmentally responsible manner, according to state and/or federal (EPA) recommendations. The fuel can be returned to the tank.

Step 3: Remove the secondary filter, if applicable, and do one of the following:

- Replace the filter with a fuel diverter cap.
- Remove the filter head and connect the fuel hoses together.

Step 4: Mount the Fuel Pro in the desired location keeping the following points in mind:

- **Mounting the Fuel Pro directly on the engine is NOT RECOMMENDED.**
- Mount vertically with the cover and element pointing up.
- Make sure there is enough top and side clearance for the cover to be conveniently removed for filter replacement.

⚠ **CAUTION:** The Fuel Pro MUST be installed so that the Filter Element is above the "FULL" level of the fuel tank.

Step 5: Route the fuel supply line from the fuel tank to the Fuel Pro inlet. Route a fuel line from the Fuel Pro outlet to the fuel pump inlet.

Step 6: To minimize restrictions, observe the following guidelines when plumbing the system.

- Keep the fuel line routing as smooth as possible with no low hanging loops which can trap water.
- Use 90° elbows only when necessary.
- If the fuel hoses are made up to length on the job, be sure that the inner liner of the fuel hose is not cut by the fitting, creating potential check valve effects. Also make sure hoses are clean and free of debris before installing.

⚠ **CAUTION:** To avoid damaging the aluminum fuel processor body, do not overtighten fuel lines or fuel line fittings.

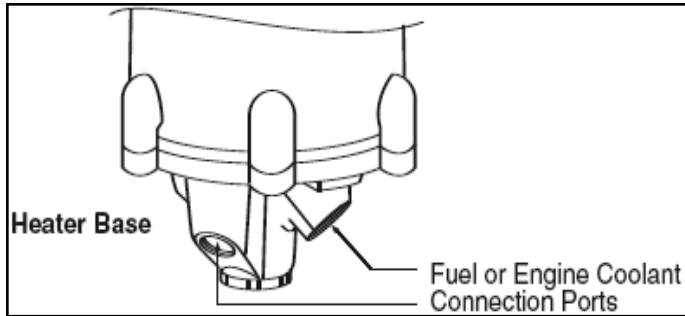

Figure 1

FUEL HEATING OPTIONS

Note: The Engine Return Fuel Heat and Engine Coolant Heat options apply ONLY to the heater base shown in Figure 1. If the bottom plate is flat with 1/2" NPT ports, only the electric pre-heater can be used.

Engine Return Fuel Heat

Electronic unit injected engines can use return fuel as the fluid heat for the Fuel Pro. Route the return fuel line from the engine into the heater base of the Fuel Pro. Either heater port will work as an inlet. Connect a second fuel return line from the heater base to the fuel tank return port.

Engine Coolant Heat

To use engine coolant as the Fuel Pro heating fluid, connect a hose (Braided #6 or #8 hose) from the high pressure side of the engine coolant system to the Fuel Pro heater base (see Figure 1). Either heater port will work as an inlet. Route another hose from the heater base to a low pressure port in the coolant system. DO NOT route into the cab heater system.

Optional Electric Pre-heater

The electric pre-heater can be used with heated systems such as the ones described above or with unheated systems. To install, follow the wiring diagram in Figure 4.

Note: When wiring the electric pre-heater, use a fuse – NOT a circuit breaker.

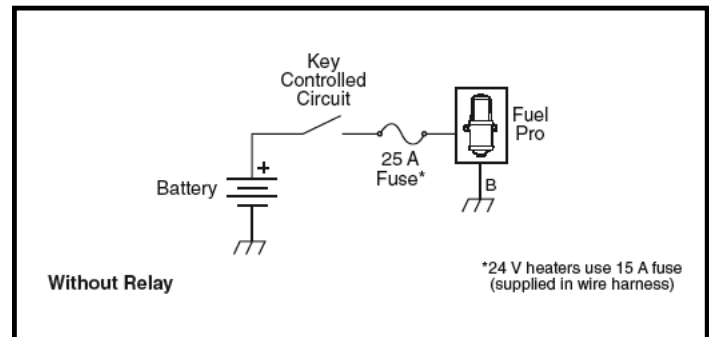
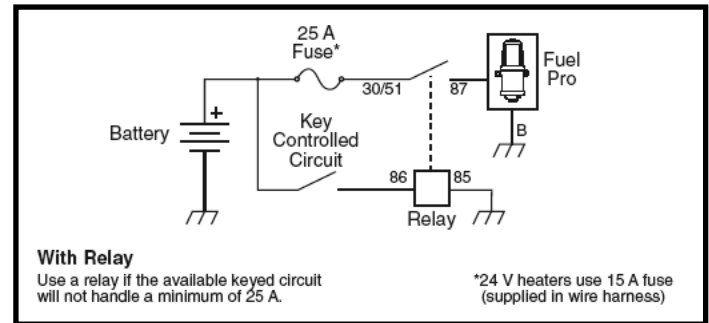

Figure 2

Note: Refer to F3099 for instruction on installing a 120VAC pre-heater

Filter Change Procedure

Step 1: Turn off the engine. Loosen the vent cap to break the air lock in the filter.

Step 2: Open the drain valve and drain the fuel level below the collar, then close the drain valve.

Step 3: Using the Collar Wrench (part number 382002), remove the clear cover from the fuel processor by removing the collar. Discard the o-ring from the base of the cover. (A new o-ring seal is supplied with the new filter.) Remove the filter element from the Fuel Pro by pulling upward and twisting slightly. Be sure the sealing grommet is removed from the center stud. Using a clean shop rag, clean the cover, the collar and threads on the Fuel Pro body.

Step 4: Install the new filter element (supplied with a sealing grommet already inserted into the element) on the processor center stud by pushing down and twisting slightly. After checking to make sure the new o-ring seal (supplied with the filter) at the base of the cover is in place, install the cover and collar. Hand tighten the collar until seated. Use Simultaneously apply downward pressure to the top of the clear cover until it is seated on the body of the Fuel Pro and hand tighten the collar until it no longer spins freely. Torque the cover assembly with the collar wrench by rotating the collar clockwise two additional ribs using the collar wrench (~18 ft-lbs).

Step 5: Remove the vent cap. Fill the clear cover with enough clean fuel to cover the bottom half of the filter element. Make sure the new o-ring (supplied with the filter) is installed on the vent cap. Reinstall the vent cap.

Step 6: Start the engine. When the lubrication system reaches its normal operating pressure, increase engine RPM for one minute.

Note: The clear filter cover will not fill completely during engine operation. It will gradually fill over time as the filter becomes clogged. The filter element does not need to be changed until the fuel level has risen to the top of the filter element.

Priming the System

Step 1: Check to make sure the drain valve at the base of the Fuel Pro is closed.

Step 2: Remove the vent cap from the top of the clear cover. Fill the Fuel Pro full of clean fuel. Reinstall the vent cap and tighten by hand only.

Step 3: Start the engine. When the lubrication system reaches its normal operating pressure, increase engine speed to high idle for one to two minutes. After the air is

purged loosen the vent cap until the fuel level drops to just above the collar. Tighten the vent cap.

Note: The clear filter cover will not fill completely during engine operation. It will gradually fill over time and the fuel level will rise as the filter becomes clogged.

Emergency Temporary Filter Replacement

Step 1: Follow Steps 1 through 3 of the "Filter Change Procedure".

Step 2: If there is a filter grommet on the filter stud, remove it.

Step 3: Install an engine spin-on filter (part number FF105, for example) on the threaded stud.

Step 4: Install the cover, spring, seal and collar over the filter for later reuse and to guard against loss.

Step 5: Start the engine. Raise the RPM for one minute to purge the air from the system.

Draining Contaminates

Step 1: Turn off the engine and open the filter vent.

Step 2: Place a cup under the drain valve at the base of the Fuel Pro and open the drain valve.

Step 3: Water will flow into the cup. When fuel begins to flow out of the drain, close the drain valve. (Drain the minimum amount of fuel possible.)

Step 4: Close the vent cap.

Step 5: Start the engine. Raise the RPM for one minute to purge the air from the system. Tighten the vent cap

Suggested Preventive Maintenance

Weekly - Drain water.

Every Filter Change - Change o-rings and grommet (included with new filter).

Every 12 Months - Check all electrical connections for corrosion. Check all fuel fittings for leaks.

Extreme winter or salt corrosion environments may require lubrication of the top collar threads with antiseize lubricant every 180 days.

Call customer support for OEM Part Numbers.



A. Vent Cap Assembly

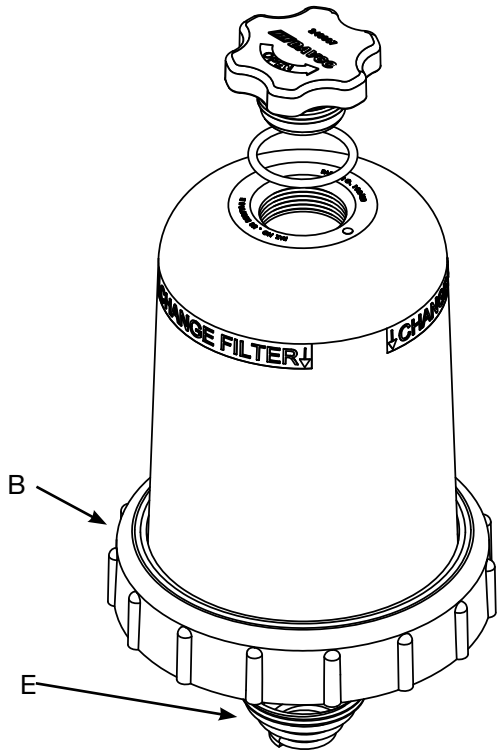

D. Cover, Collar, Vent Cap & Spring

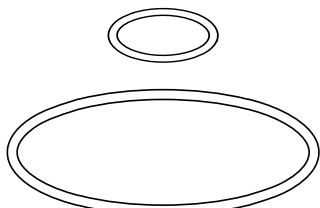

C. O-Ring Kit

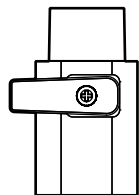

J. Drain Valve

	Part name	Part number
A	Vent Cap Assembly	240023
B	Collar	102425
C	O-Ring Kit	380072
D	Cover, Collar, Vent Cap & Spring	103100
E	Spring	380056
F	Filter Element - call customer service	
H	Check Valve Service Kit	102654
I	Check Valve Assembly, includes check valve body.	103098
J	Drain Valve	102008
K	Collar/Vent Cap Wrench, Metal	380134
L	Collar/Vent Cap Wrench, Composite	382002

